

FEATURES

- Input for Strain Gauge
- Input range configurable from 0÷10 mV up to 0÷200 mV or from ± 5 mV up to ± 200 mV
- Accurate bridge excitation voltage at 3.6 and 10 Vdc with current limiter
- Isolated power supply source for passive loads on output
- Input and output ranges configurable by DIP-switches
- Galvanic isolation at 2000 Vac between input, power supply and output
- Good accuracy and performance stability
- EMC compliant – CE mark
- DIN rail mounting in compliance with EN-50022 and EN-50035



GENERAL DESCRIPTION

The converter DAT 5025 is designed to provide on its output a voltage or current signal linear and proportional with the output voltage coming from the output of a bridge transducers applied on its input.

The user can program the bridge excitation voltage value, the input and the output ranges by the proper DIP-switches available after opening the suitable door located on the side of device (see "Input ranges table" and "Output ranges table" sections).

The regulation of Zero and Span values is made by the ZERO and SPAN potentiometers located on the top of device.

The 2000 Vac isolation between input, power supply and output eliminates the effects of all ground loops eventually existing and allows the use of the converter in heavy environmental conditions found in industrial applications.

The DAT 5025 provides on the output side an auxiliary supply source to connect both active and passive loads.

It has been made in compliance with the EEC/336/89 standard on the Electromagnetic Compatibility.

It is housed in a plastic enclosure of 12.5 mm thickness suitable for DIN rail mounting in according to EN-50022 and EN-50035 standards .

OPERATIVE INSTRUCTIONS

The converter DAT 5025 must be powered by a direct voltage included in the 18 V to 30 V range. The power supply must be applied between the terminals Q (+Vdc) and R (GND1).

The output connections must be made as shown in the section "Output connections".

Voltage output: between the terminals N (Out V) and M (GND2); **passive current output:** between the terminals P (Out I) and M (GND2) for the sink currents; **active current output :** between the terminals O (Vaux) and P (Out I) for the source currents.

The input connections must be made as shown in the section "Input connections".

The bridge transducer must be powered between the terminals E (+EXC) and F(-EXC); the bridge's output voltage signal must be connected between the terminals G or H(+ IN) I or L (- IN).

The configuration of the bridge excitation voltage, the input and output ranges values is made by DIP-switches (refer to the section "Input ranges table" and "Output ranges table").

After the converter configuration, it is necessary to calibrate it using the ZERO and SPAN regulations; this operation is illustrated in the section "DAT 5025: Configuration and calibration".

To install the device refer to the section "Installation instructions".

TECHNICAL SPECIFICATIONS (Typical @ 25 °C and in nominal conditions)

Input	
Sensor type	Strain Gauge
Input signal(configurable)	From 0÷10 mV up to 0÷200 mV and from ± 5 mV up to ± 200 mV
Bridge excitation voltage (Vexc)	3.60 Vdc ± 0.1% (with bridge's resistance included between 100 Ω and 10 KΩ) 10 Vdc ± 0.1% (with bridge's resistance included between 300 Ω and 10 KΩ)
Thermal Drift	± 0.01 % of the selected value/°C
Bridge excitation current	65 mA max.
Output	
Signal type (configurable)	Current: 4 ÷ 20 mA, 0 ÷ 20 mA, Voltage: 0÷10 V, 2÷10 V, 0÷5 V, 1÷5 V
Zero regulation	± 40 % max.
Span regulation	± 40 % max.
Load resistance (Rload)	Current output: <= 500 Ω, Voltage output: >= 5 KΩ
Auxiliary supply (Aux. Supply out)	12 Vdc min @ 20 mA
Performances	
Calibration error	± 0.1 % of f.s.
Linearity error (*)	± 0.1 % of f.s.
Thermal drift	0.01 % of f.s./°C
Response time (from 10 to 90 % of f.s.)	40 ms
Power supply voltage (**)	18÷30 Vdc
Current consumption(***)	Current output: 120 mA max. Voltage output: 80 mA max.
Electromagnetic Compatibility (EMC) (for industrial environments)	Immunity: EN 61000-6-2; Emission : EN 61000-6-4
Isolation voltage	2000 Vac, 50 Hz, 1 min.
Operating temperature	-20 ÷ 60 °C
Storage temperature	- 40 ÷ 85 °C
Relative humidity (non cond.)	0 ÷ 90%
Weight	approx. 90 g

(*) inclusive of hysteresis and power supply variation.

(**) internally protected against polarity reversion.

(***)Current: with both bridge excitation voltage at minimum load and output Auxiliary supply operative; Voltage: with bridge excitation voltage operative at minimum load.

DAT 5025: CONFIGURATION & CALIBRATION

- 1) Refer to the "Input ranges table", determine in the column " Input " the position of the input value.
Refer to the " Output ranges table " and determine in the column " Output " the position of the output value.
In the correspondent lines is shown how to set the DIP-switches .
- 2) Set the DIP-switches as indicated .
- 3) Set the minimum value of the input range .
- 4) By the ZERO potentiometer calibrate the output at the minimum value .
- 5) Set the maximum value of the input range .
- 6) By the SPAN potentiometer calibrate the output at the maximum value .
- 7) Repeat the operation from the step 4 to the step 7 until the output value will be correct (3 attempts typically required).

Configuration ex. : in: 0÷10 mV, V_{exc} = 10 Vdc, out 0÷10 Vdc
Input switches configuration (SW1): On, On, On, On, Off, Off(*).
Output switches configuration (SW2): Off, Off, Off, On

(*) = switch for the configuration of the Bridge excitation voltage value .

INPUT RANGES TABLE

INPUT	DSI				
	1	2	3	4	5
0 ÷ 10 mV	●	●	●	●	
0 ÷ 20 mV	●	●	●		
0 ÷ 50 mV	●		●	●	
0 ÷ 100 mV			●	●	
0 ÷ 200 mV			●		
± 5 mV	●	●	●	●	●
± 10 mV	●	●	●		●
± 20 mV	●	●			●
± 50 mV			●	●	●
± 100 mV			●		●
± 200 mV					●

OUTPUT RANGE TABLE

OUTPUT	DSO			
	1	2	3	4
0 ÷ 20 mA				
4 ÷ 20 mA	●	●		
1 ÷ 5 V	●	●	●	●
0 ÷ 5 V			●	●
0 ÷ 10 V				●

EXCITATION VOLTAGE RANGE TABLE

BRIDGE VOLT. (V _{exc})	DSI
3.60 Vcc	●
10 Vcc	

● = DIP SWITCHES " ON"

INSTALLATION INSTRUCTIONS

The DAT 5025 device is suitable for fitting to DIN rails in the vertical position. For optimum operation and long life follow these instructions:

When the devices are installed side by side it may be necessary to separate them by at least 5 mm in the following case:

- If panel temperature exceeds 45°C and **at least one** of the overload conditions exists.
- If panel temperature exceeds 35°C and **both** the overload conditions exist.

Overload conditions:

- Use of the current output (terminal P).
 - Use of output auxiliary supply (terminal O).
- Make sure that sufficient air flow is provided for the device avoiding to place raceways or other objects which could obstruct the ventilation slits. Moreover it is suggested to avoid that devices are mounted above appliances generating heat; their ideal place should be in the lower part of the panel. Install the device in a place without vibrations. Moreover it is suggested to avoid routing conductors near power signal cables (motors, induction ovens, inverters, etc...) and to use shielded cable for connecting signals.

Datexel s.r.l. reserves its right to modify totally or in part the characteristics of its product without notice at any time .

ISOLATIONS STRUCTURE

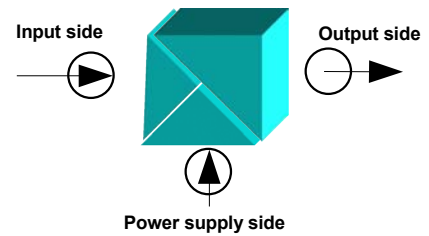

DAT 5025: CONNECTIONS

INPUT CONNECTIONS

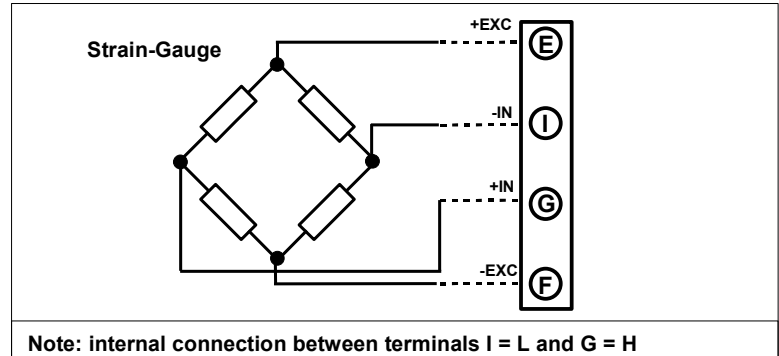

POWER SUPPLY CONNECTIONS

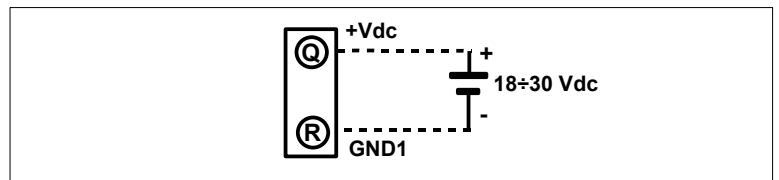

OUTPUT CONNECTIONS

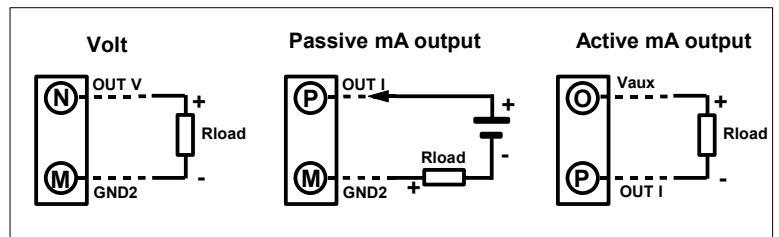

DIMENSIONS (mm) & REGULATIONS

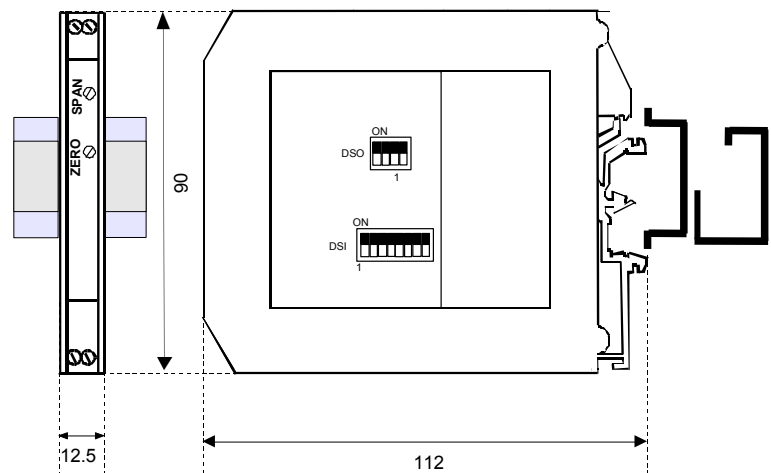

HOW TO ORDER

The DAT 5025 is supplied as requested on the order. In case of the configuration is not specified, the parameters must be set by the user.

ORDER CODE EXAMPLE: DAT 5025 0÷10 mV - 0÷10 V - 10 Vdc

