

FEATURES

- Interface Ethernet 10/100 Base-T Modbus TCP
- RJ45 Connector
- Configuration via integrated web server
- Serial interface RS-485
- Modbus RTU Master
- Baud rate up to 115.2 Kbps
- Distance up to 1200 m, up to 32 modules connected in multipoint
- Connection by removable screw-terminals
- LED signalling for Link/Act Ethernet, power supply
- Galvanic isolation on all the ways
- EMC compliant – CE mark
- In compliance to EN-50022 DIN rail mounting



GENERAL DESCRIPTION

The device DAT3580 GW allows to connect all the devices with Modbus RTU of a RS-485 serial line to the Ethernet with Modbus TCP protocol. By the integrated web server it is possible to configure the option of Modbus TCP (IP address, subnet mask, etc..) and Modbus RTU (baud rate, etc...) The device realizes a full electrical isolation between the lines, introducing a valid protection against the effects of all ground loops eventually existing in industrial applications.

The LEDs of signalling of Ethernet and the serial line communication activity and power supply allow a direct monitoring of the system functionality. The connection is made by removable screw-terminals (inputs and power supply) and RJ45 plug (Ethernet).

The device is housed in a 2 module DIN rough self-extinguishing plastic box for mounting on EN-50022 standard DIN rail.

USER INSTRUCTIONS

The DAT3580 GW can be connected directly to the SCADA, HMI o OPC server on the market that implement the Modbus TCP protocol. It is possible to connect at the same time up to 8 clients; each command sent by a client over the Ethernet with Modbus TCP protocol is processed and re-transmitted over the RS-485 with Modbus RTU protocol to the slave devices connected. As soon as the response from the slave is received, it is processed and re-transmitted to client which sent the query. By the integrated web server it is possible to configure the settings of network and serial line from any remote terminal.

TECHNICAL SPECIFICATIONS (Typical @ 25 °C and in the nominal conditions)

In compliance to		Ethernet IEEE 802.3 e RS485	POWER SUPPLY	
Ethernet interface Protocol		Ethernet 10/100Base-T Modbus TCP	DC Power Supply	18 ÷ 30 Vdc
			AC Power Supply	12 ÷ 30 Vac
			Current consumption	55 mA max.
RS485 Interface			ISOLATION	
Baud rate		configurable up to 115.2 Kbps	Ethernet / RS485	1500 Vac, 50 Hz, 1 min.
Parity		configurable as even / odd / space	Power supply / RS485	1500 Vac, 50 Hz, 1 min.
Stop Bit		configurable as 1 or 2	ENVIRONMENTAL CONDITIONS	
Max. Distance / Baud Rate Ratio (recommended) (1)		1.2 Km @ 38400 bps 2 Km @ 19200 bps 3 Km @ 9600 bps 4 Km @ 4800 bps 5 Km @ 2400 bps 7 Km @ 1200 bps	Operative Temperature	-20°C .. +60°C
			Storage Temperature	-40°C .. +85°C
			Humidity (not condensed)	0 .. 90 %
			Maximum Altitude	2000 m
			Installation	Indoor
			Category of installation	II
			Pollution Degree	2
Number of modules in multipoint		32 max.	MECHANICAL SPECIFICATIONS	
Switching time TX/RX (RS485)		150 us.	Material	Self-extinguish plastic
Termination resistance		120 Ohm	IP Code	IP20
			Wiring	wires with diameter 0.8÷2.1mm ² /AWG 14-18
			Tightening Torque	0.8 N m
			Mounting	in compliance to DIN rail standard EN-50022 and EN-50035
			Weight	about 80 g
Connections			CERTIFICATIONS	
Ethernet		RJ-45	EMC (for industrial environments)	
RS-485		removable screw terminals pitch 3.81 mm	Immunity	EN 61000-6-2
Power supply		removable screw terminals pitch 5.08 mm	Emission	EN 61000-6-4

(1) – The maximum distance depends of: number of devices connected, type of cabling, noises, etc...

INSTALLATION INSTRUCTIONS

The DAT3580 GW is suitable for fitting to DIN rails in the vertical position. For optimum operation and long life follow these instructions:

When the devices are installed side by side it may be necessary to separate them by at least 5 mm.

When the devices are installed beside a power supply unit it is necessary to separate them by at least 10 mm.

To connect the serial line RS485 it is suggested to use the cable Belden type 9842 suitable for RS485.

Make sure that sufficient air flow is provided for the device avoiding to place raceways or other objects which could obstruct the ventilation slits. Moreover it is suggested to avoid that devices are mounted above appliances generating heat; their ideal place should be in the lower part of the panel.

Install the device in a place without vibrations. Moreover it is suggested to avoid routing conductors near power signal cables (motors, induction ovens, inverters etc...) and to use shielded cable to connect signals.

CONFIGURATION BY WEB SERVER

To configure the device by web server:

- Connect to the device via an internet browser
- Select the language
- Click on "Settings"
- Insert User Name (factuser) and Password (factpwd)
- Modify the parameters as desired
- Click on "Save Settings" and wait for that the reset occurs

FUNCTION BUTTON "RST"

To reload the default parameters of the device, keep pushed the button "RST" on the front side of the instrument with device powered for at least 5 seconds.

The led PWR will become red and the reset of the device will occur.

The following parameters will be load:

Ethernet:

- IP Address : 192.168.1.100
- Subnet Mask : 255.255.255.0
- Gateway Mask: 192.168.1.1

RS485:

- Baud rate 38400 bps
- Parity: none
- Stop bit : 1

The modbus address is internally fixed to 255.

TERMINATION RESISTANCE SELECTION FOR RS485

In the low part of the device it is possible to access to the dip-switch of selection of termination resistance.

If the cursor is on OFF position (to left) the termination resistance won't be inserted.

If the cursor is on ON position (to right) the termination resistance of 120 ohm will be inserted across the lines of the RS485.

OFF  ON

WIRING

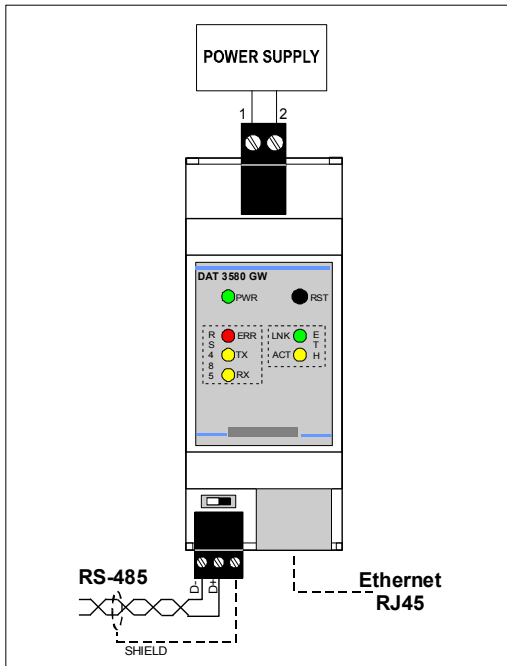

ISOLATIONS STRUCTURE



CONNECTIONS

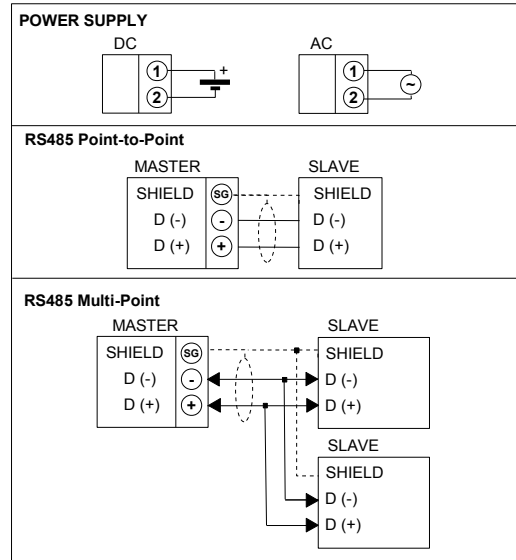

LIGHT SIGNALLING

LED	COLOUR	STATE	DESCRIPTION
PWR	GREEN	ON	Device powered
		OFF	Device not powered
ERROR	RED	BLINK	RS485 net error occurred If button RST pushed – Reset of device occurred
		OFF	No error
TX	YELLOW	BLINK	Stream of data over transmission line of RS-485 (the blinking frequency depends on Baud-rate)
		OFF	No data over transmission line of RS-485
RX	YELLOW	BLINK	Stream of data over receiving line of RS-485 (the blinking frequency depends on Baud-rate)
		OFF	No data over receiving line of RS-485
LNK	GREEN	BLINK	Device connected to the Ethernet
		OFF	No data received from the Ethernet
ACT	YELLOW	BLINK	Stream of data over the Ethernet
		OFF	No data received from the Ethernet

MECHANICAL DIMENSIONS (mm)

VIEW WITH TERMINAL COVER

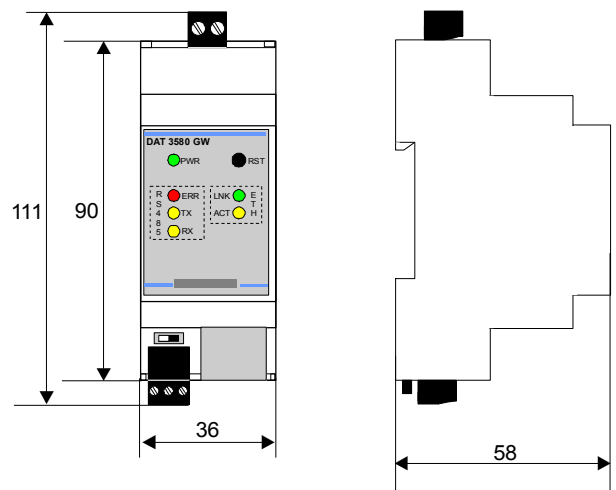

HOW TO ORDER

" DAT 3580 GW "



Configuration:

IP Address: . . .

SubNet Mask: . . .

Gateway: . . .

RS485 settings: Baud Rate, bit, parity, stop bit

 = Requested
 = Optional